

Lead Free Brass Horizontal Check Valve



Threaded Connection • 200 WOG



T-501G

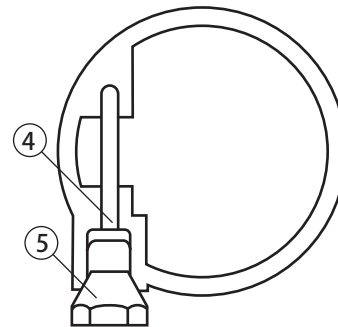
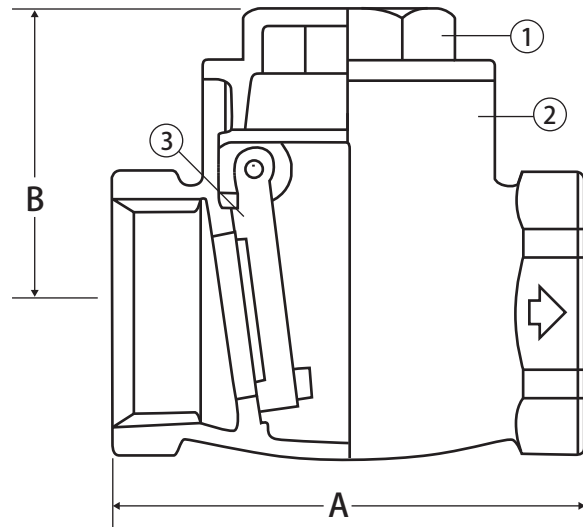

Features

- Residential and commercial applications
- Wetted surfaces contain less than .25% lead content

Approvals

- IAPMO Certified
 - NSF 372
- ANSI B1.20.1

Pressure Rating

- 200 WOG

Install 5 pipe diameters minimum downstream from pump discharge or changes in direction to avoid flow turbulence. Flow straighteners may be required in extreme cases.

Note: On pump discharge, the preferred check valves are: inline, spring assisted, center-guided, lift checks.

Warning: Do Not Use For Reciprocating Air Compressor Service

Material Specifications

No.	Part	Materials
1	Cap	Lead Free Cast Brass
2	Body	Lead Free Cast Brass
3	Disc	Lead Free Forged Brass
4	Hinge Pin	Lead Free Brass
5	Screw	Lead Free Brass

Dimensions

Part No.	Size	A	B
105-103G	1/2"	2.13	1.54
105-104G	3/4"	2.33	1.62
105-105G	1"	2.72	1.77
105-106G	1-1/4"	3.11	2.01
105-107G	1-1/2"	3.51	2.25
105-108G	2"	4.30	2.68
105-109G	2-1/2"	5.32	3.35
105-110G	3"	6.30	3.86
105-111G	4"	7.49	4.53



WARNING: This product can expose you to chemicals including lead, which is known to the State of California to cause cancer, and lead, which is known to the State of California to cause birth defects or other reproductive harm. For more information go to www.P65Warnings.ca.gov.