

For Health Hazard Applications

Job Name _____

Contractor _____

Job Location _____

Approval _____

Engineer _____

Contractor's P.O. No. _____

Approval _____

Representative _____

LEAD FREE*

Series LF909 Reduced Pressure Zone Assemblies

Sizes: 2½" – 10" (65–250mm)

Series LF909 Reduced Pressure Zone Assemblies are designed to provide cross-connection control protection of the potable water supply in accordance with national plumbing codes. This series can be utilized in a variety of installations, including health hazard cross-connections in plumbing systems or for containment at the service line entrance. With its exclusive relief valve design incorporating the "air-in/water-out" principle, it provides substantially improved relief valve discharge performance during the emergency conditions of combined backsiphonage and backpressure with both checks fouled. The LF909 features Lead Free* construction to comply with Lead Free* installation requirements.

Features

- Replaceable seats
- Stainless steel internal parts
- No special tools required for servicing
- Captured spring check assemblies
- Fused epoxy coated & lined checks
- Industrial strength sensing hose
- Field reversible relief valve
- Air-in/water-out relief valve design provides maximum capacity during emergency conditions

Available Models

Suffix:

LF –	without shutoff valves
NRS –	non-rising stem resilient seated gate valves
OSY –	UL/FM outside stem & yoke resilient seated gate valves
QT-FDA –	FDA epoxy coated quarter-turn ball valves
S-FDA –	FDA epoxy coated strainer

Note: The installation of a drain line is recommended. When installing a drain line, an air gap is necessary.

Now Available
WattsBox Insulated Enclosures.

For more information, send for literature ES-WB.

NOTICE

Inquire with governing authorities for local installation requirements

*The wetted surface of this product contacted by consumable water contains less than 0.25% of lead by weight.

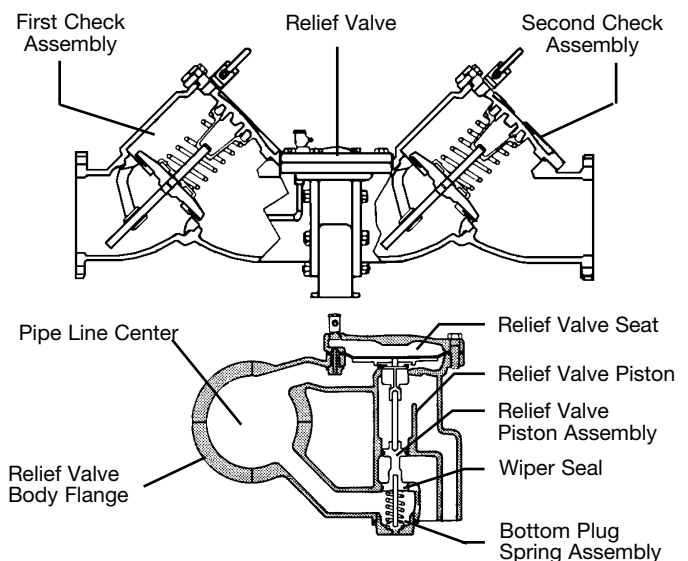
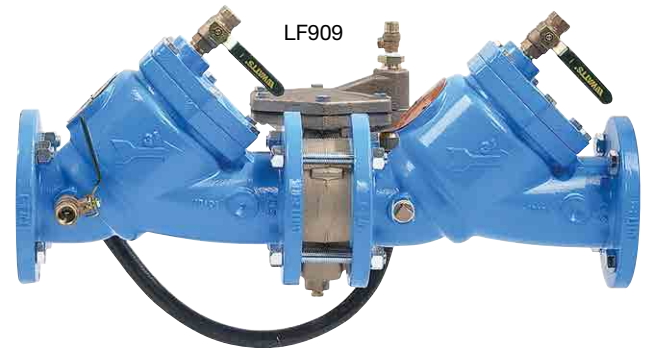

Specifications

A Reduced Pressure Zone Assembly shall be installed at each cross-connection to prevent backsiphonage and backpressure backflow of hazardous materials into the potable water supply. The assembly shall consist of a pressure differential relief valve located in a zone between two positive seating check valves and captured springs. Backsiphonage protection shall include provision to admit air directly into the reduced pressure zone via a separate channel from the water discharge channel. The assembly shall include two tightly closing shutoff valves before and after the valve and test cocks. The Lead Free* Reduced Pressure Zone Assembly shall comply with state codes and standards, where applicable, requiring reduced lead content. The assembly shall meet the requirements of ASSE Std. 1013; AWWA Std. C511-92; CSA B64.5; and UL Classified File No. EX3185. Listed by IAPMO (UPC). Approved by the Foundation for Cross-Connection Control and Hydraulic Research at the University of Southern California. The assembly shall be a Watts Series LF909.

Watts product specifications in U.S. customary units and metric are approximate and are provided for reference only. For precise measurements, please contact Watts Technical Service. Watts reserves the right to change or modify product design, construction, specifications, or materials without prior notice and without incurring any obligation to make such changes and modifications on Watts products previously or subsequently sold.

Materials

Check Valve Bodies: FDA epoxy coated cast iron
 Seats: Stainless steel
 Trim: Stainless steel
 Relief Valve Body: 2½"-3" (60-80mm) Lead Free* cast copper silicon alloy
 4"-10" (100-250mm) FDA epoxy coated cast iron
 Test Cocks: Lead Free* copper silicon alloy

Pressure – Temperature

Temperature Range: 33°F-110°F (0.5°C-43°C) continuous,
 140°F (60°C) intermittent
 Maximum Working Pressure: 175psi (12.06 bar)

Standards

AWWA C511-92
 IAPMO PS 31, SBCCI (Standard Plumbing Code)
 USC manual for Cross-Connection Control, 8th Edition

*The wetted surface of this product contacted by consumable water contains less than 0.25% of lead by weight.

Capacity

*Typical maximum flow rate (7.5 feet/sec.)

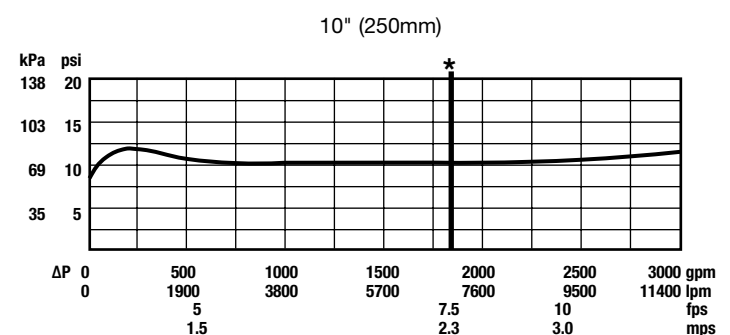
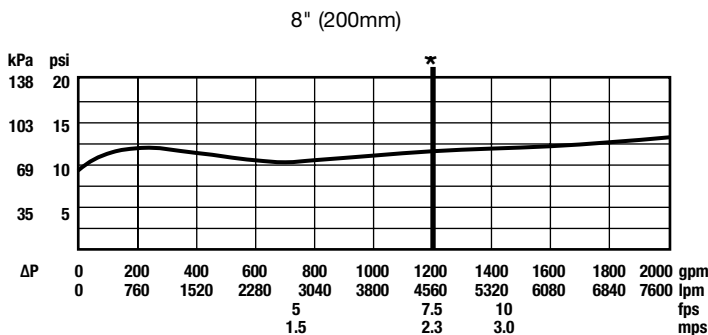
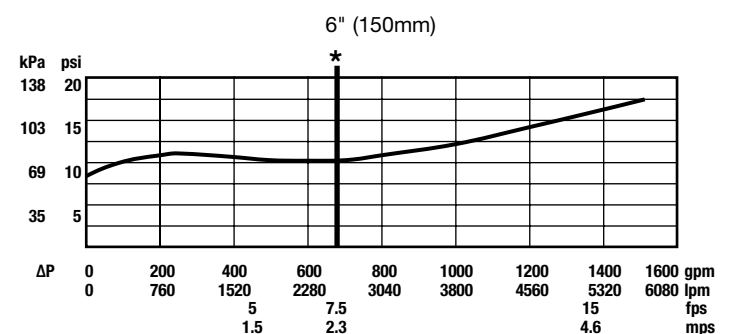
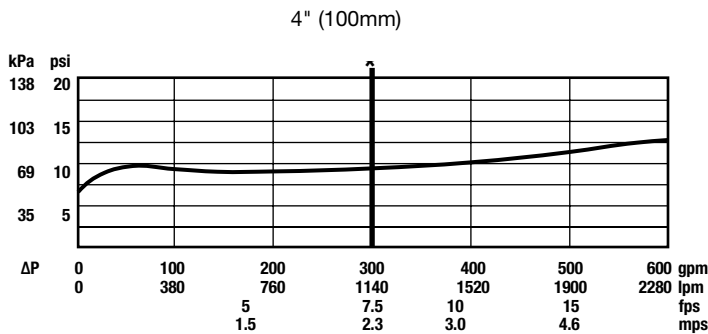
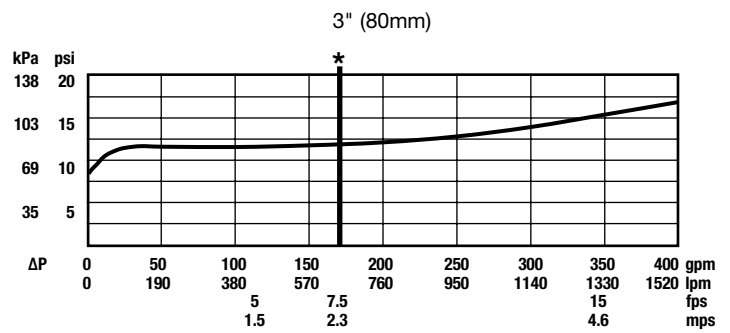
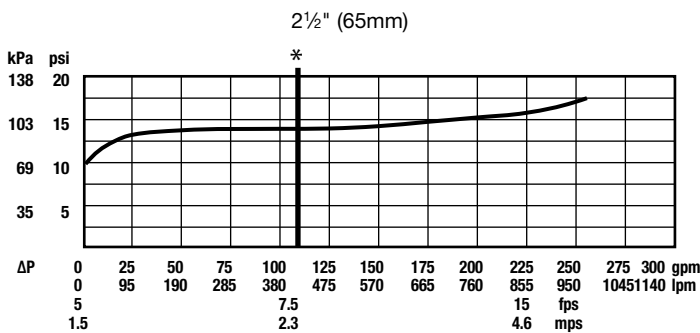

How It Operates

The unique relief valve construction incorporates two channels: one for air, one for water. When the relief valve opens, as in the accompanying air-in/water-out diagram, the right-hand channel admits air to the top of the reduced pressure zone, relieving the zone vacuum. The channel on the left then drains the zone to atmosphere. Therefore, if both check valves foul, and simultaneous negative supply and positive backpressure develops, the relief valve uses the air-in/water-out principle to stop potential backflow.

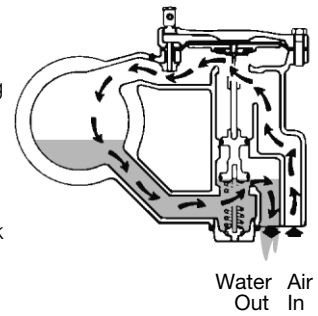

Approvals



Approved by the Foundation for Cross-Connection Control and Hydraulic Research at the University of Southern California.

Dimensions – Weights

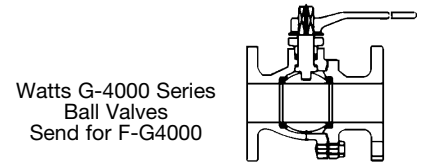
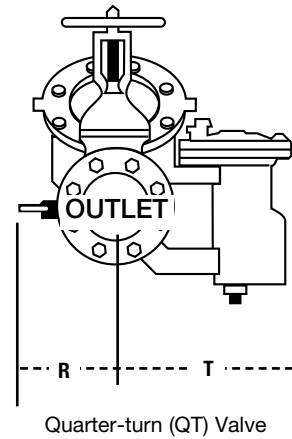
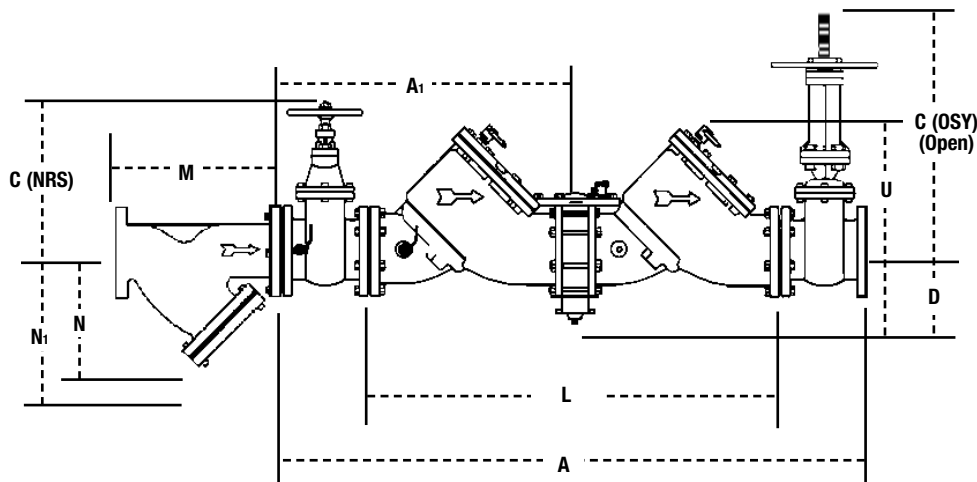

NOTE: Valve may be furnished with (2) OSY or (2) NRS Shutoffs.

NOTE: Relief valve section is reversible, therefore, can be on either side and is furnished standardly as shown.

SIZE (DN)		DIMENSIONS										WEIGHT															
in.	mm	A		A1		C clearance for check		D	L	U	R	R (QT)		T		NRS		OSY		QT							
		in.	mm	in.	mm	(OSY)*	(NRS)					in.	mm	in.	mm	in.	mm	in.	mm	lbs.	kgs.	lbs.	kgs.	lbs.	kgs.		
2½	65	41¼	1048	20⅝	524	16⅝	416	9⅞	238	5¼	133	26⅞	663	11	279	4	102	16	406	9⅞	230	195	88.4	198	89.8	182	82.6
3	80	42¼	1073	21¼	540	18⅞	479	10¼	260	5¼	133	26⅞	663	11	279	5	127	16	406	9⅞	230	225	102	230	104	190	86
4	100	55⅞	1400	27⅞	702	22¾	578	12¾	310	6	152	37	940	14	356	6	152	19¾	502	14⅞	365	455	206	470	213	352	160
6	150	65½	1664	32¾	832	30⅞	765	16	406	6	152	44½	1130	16	406	11	279	26	660	14⅞	365	718	326	798	362	762	346
8	200	78½	2000	39⅞	1000	37¾	959	19⅞	506	9¾	248	55¼	1403	21	533	11¼	286	11¼	286	19¼	489	1350	612	1456	660	2286	1037
10	250	93⅞	2378	46⅞	1190	45¼	1162	23⅞	605	9¾	248	67⅞	1711	21	533	12½	318	12½	318	21	533	2160	980	2230	1011	3716	1685

*UL, FM approved backflow preventers must include UL/FM approved OSY gate valves.

Strainer Dimensions

NOTICE

The information contained herein is not intended to replace the full product installation and safety information available or the experience of a trained product installer. You are required to thoroughly read all installation instructions and product safety information before beginning the installation of this product.

SIZE (DN)		DIMENSIONS				WEIGHT			
in.	mm	M		N1†		N		lbs.	kgs.
		in.	mm	in.	mm	in.	mm		
2½	65	10	254	10	254	6½	165	28	12.7
3	80	10⅞	257	10	254	7	178	34	15.4
4	100	12⅞	308	12	305	8¼	210	60	27
6	150	18½	470	20	508	13½	343	133	60
8	200	21⅞	549	22¾	578	15½	394	247	112
10	250	26	660	28	711	18½	470	370	168

† – Dimension required for screen removal

Air Gap Dimensions

When installing a drain line on Series 909 backflow preventers that are installed horizontally, use 909 AG series air gaps.

IRON BODY MODEL NO.	ORDERING CODE	SERIES/SIZES	DIMENSIONS			WEIGHT				
			A	B	C	lbs	kgs			
			in.	mm	in.	mm	in.	mm	lbs	kgs
909AG-F	881378	1¼" – 3" 009/909 1¼" – 2" 009 M1 2" 009 M2	4⅞	111	6¾	171	2	51	3.25	1.47
909AG-K	881385	4" – 6" 909 8" – 10" 909 M1	6⅞	162	9⅞	244	3	76	6.25	2.83
909AG-M	881387	8" – 10" 909	7⅞	187	11¼	286	4	102	15.5	7.03

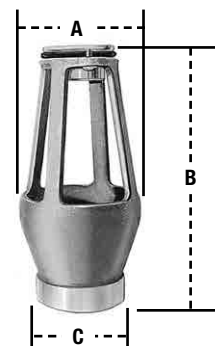

For flange size backflow preventers installed vertically (flow down), a fabricated air gap is recommended.

For additional information, visit our web site at: Watts.com



A Watts Water Technologies Company

USA: Tel: (978) 689-6066 • Fax: (978) 975-8350 • Watts.com

Canada: Tel: (905) 332-4090 • Fax: (905) 332-7068 • Watts.ca

Latin America: Tel: (52) 81-1001-8600 • Fax: (52) 81-8000-7091 • Watts.com